



OWNER'S MANUAL

JML-1014 Mini Lathe



JET EQUIPMENT & TOOLS, INC.
A WMH Company
www.jettools.com

P.O. BOX 1349
Auburn, WA 98071-1349
e-mail jet@jettools.com

253-351-6000
Fax 800-274-6840
M-708351 1-00

Important Information

**2-YEAR
LIMITED WARRANTY**

**JET offers a two-year limited
warranty on this product**

REPLACEMENT PARTS

Replacement parts for this tool are available directly from JET Equipment & Tools.

To place an order, call 1-800-274-6848. Please have the following information ready:

1. Visa, MasterCard, or Discover Card number
2. Expiration date
3. Part number listed within this manual
4. Shipping address other than a Post Office box.

REPLACEMENT PART WARRANTY

JET Equipment & Tools makes every effort to assure that parts meet high quality and durability standards and warrants to the original retail consumer/purchaser of our parts that each such part(s) to be free from defects in materials and workmanship for a period of thirty (30) days from the date of purchase.

PROOF OF PURCHASE

Please retain your dated sales receipt as proof of purchase to validate the warranty period.

LIMITED TOOL AND EQUIPMENT WARRANTY

JET makes every effort to assure that its products meet high quality and durability standards and warrants to the original retail consumer/purchaser of our products that each product be free from defects in materials and workmanship as follows: 2 YEAR LIMITED WARRANTY ON THIS JET PRODUCT. Warranty does not apply to defects due directly or indirectly to misuse, abuse, negligence or accidents, repairs or alterations outside our facilities or to a lack of maintenance. JET LIMITS ALL IMPLIED WARRANTIES TO THE PERIOD SPECIFIED ABOVE FROM THE DATE THE PRODUCT WAS PURCHASED AT RETAIL. EXCEPT AS STATED HEREIN, ANY IMPLIED WARRANTIES OR MERCHANTABILITY AND FITNESS ARE EXCLUDED. SOME STATES DO NOT ALLOW LIMITATIONS ON HOW LONG THE IMPLIED WARRANTY LASTS, SO THE ABOVE LIMITATION MAY NOT APPLY TO YOU. JET SHALL IN NO EVENT BE LIABLE FOR DEATH, INJURIES TO PERSONS OR PROPERTY OR FOR INCIDENTAL, CONTINGENT, SPECIAL OR CONSEQUENTIAL DAMAGES ARISING FROM THE USE OF OUR PRODUCTS. SOME STATES DO NOT ALLOW THE EXCLUSION OR LIMITATION OF INCIDENTAL OR CONSEQUENTIAL DAMAGES, SO THE ABOVE LIMITATION OR EXCLUSION MAY NOT APPLY TO YOU. To take advantage of this warranty, the product or part must be returned for examination, postage prepaid, to an authorized service station designated by our Auburn office. Proof of purchase date and an explanation of the complaint must accompany the merchandise. If our inspection discloses a defect, JET will either repair or replace the product or refund the purchase price, if we cannot readily and quickly provide a repair or replacement, if you are willing to accept such refund. JET will return repaired product or replacement at JET's expense, but if it is determined there is no defect, or that the defect resulted from causes not within the scope of JET's warranty, then the user must bear the cost of storing and returning the product. This warranty gives you specific legal rights, and you have other rights, which vary, from state to state.

JET Equipment & Tools • P.O. Box 1349, Auburn, WA 98071-1349 • (253) 351-6000

 **WARNING**

For your own safety, read this instruction manual before operating the lathe.

Wear eye protection.

Do not wear gloves, necktie, or loose clothing.

Tighten all locks before operating.

Rotate the workpiece by hand before applying power.

Rough out the workpiece before installing on the faceplate.

Do not mount a split workpiece or one containing a knot.

Use the lowest speed when starting a new workpiece.

- **KEEP GUARDS IN PLACE** and in working order.
- **REMOVE ADJUSTING KEYS AND WRENCHES.** Form the habit of checking to see that keys and adjusting wrenches are removed from the tool before turning it on.
- **KEEP THE WORK AREA CLEAN.** Cluttered areas and benches invite accidents.
- **DO NOT USE IN A DANGEROUS ENVIRONMENT.** Don't use power tools in damp or wet locations, or expose them to rain. Keep work area well lighted.
- **KEEP CHILDREN AWAY.** All visitors should be kept safe distance from the work area.
- **MAKE THE WORKSHOP KID PROOF** with padlocks, master switches, or by removing starter keys.
- **DON'T FORCE THE TOOL.** It will do the job better and safer at the rate for which it was designed.
- **USE THE RIGHT TOOL.** Don't force a tool or attachment to do a job for which it was not designed.
- **USE THE PROPER EXTENSION CORD.** Make sure you extension cord is in good condition. When using an extension cord, be sure to use one heavy enough to carry the current your product will draw. An undersize cord will cause a drop in the line voltage resulting in loss of power and overheating. **For runs up to 25 feet, use an 18 AWG or larger gauge cord. For runs up to 50 feet, use a 16 AWG or larger gauge cord. For runs up to 100 feet, use a 14 AWG or larger gauge cord. For runs up to 150 feet, use a 12 AWG or larger gauge cord. Runs over 150 feet are not recommended.** If in doubt, use the next heavier gauge. The smaller the gauge number, the heavier the cord.
- **WEAR PROPER APPAREL.** Do not wear loose clothing, gloves, neckties, rings, bracelets, or other jewelry which may get caught in moving parts. Nonslip footwear is recommended. Wear protective hair covering to contain long hair.

- **ALWAYS USE SAFETY GLASSES.** Also use face or dust masks if the cutting operation is dusty. Everyday eyeglasses only have impact resistant lenses, they are NOT safety glasses.
- **SECURE WORK.** Use clamps or a vise to hold the work when it's practical. It's safer than using your hand and it frees both hands to operate the tool.
- **DON'T OVERREACH.** Keep proper footing and balance at all times.
- **MAINTAIN TOOLS WITH CARE.** Keep tools sharp and clean for best and safest performance. Follow instructions for lubricating and changing accessories.
- **DISCONNECT TOOLS** before servicing; when changing accessories, such as blades, bits cutters, and the like.
- **REDUCE THE RISK OF UNINTENTIONAL STARTING.** Make sure the switch is in the off position before plugging in the machine.
- **USE RECOMMENDED ACCESSORIES.** Consult the owner's manual for recommended accessories. The use of improper accessories may cause a risk of injury.
- **NEVER STAND ON A TOOL.** Serious injury could occur if the tool is tipped or if the cutting tool is unintentionally contacted.
- **CHECK DAMAGED PARTS.** Before further use of the tool, a guard or other part that is damaged should be carefully checked to determine that it will operate properly and perform its intended function. Check for alignment of moving parts, binding of moving parts, breakage of parts, mounting, and any other conditions that may affect its operation. A guard or other part that is damaged should be properly repaired or replaced.
- **DIRECTION OF FEED.** Feed work into a blade or cutter against the direction of rotation of the blade or cutter only.
- **NEVER LEAVE THE TOOL RUNNING UNATTENDED. TURN THE POWER OFF.** Don't leave the tool until it comes to a complete stop.

Electrical Requirements

In the event of a malfunction or breakdown, grounding provides a path of least resistance for electric current to reduce the risk of electric shock. This tool is equipped with an electric cord having an equipment-grounding conductor and a grounding plug. The plug must be plugged into a matching outlet that is properly installed and grounded in accordance with all local codes and ordinances.

Do not modify the plug provided. If it will not fit the outlet, have the proper outlet installed by a qualified electrician.

Improper connection of the equipment-grounding conductor can result in a risk of electric shock. The conductor, with insulation having an outer surface that is green with or without yellow stripes, is the equipment-grounding conductor. If repair or replacement of the electric cord or plug is necessary, do not connect the equipment-grounding conductor to a live terminal.

Check with a qualified electrician or service personnel if the grounding instructions are not completely understood, or if in doubt as to whether the tool is properly grounded.

Use only three wire extension cords that have three-prong grounding plugs and three-pole receptacles that accept the tool's plug.*

Repair or replace a damaged or worn cord immediately.

This tool is intended for use on a circuit that has an outlet that looks the one illustrated in Figure A below. The tool has a grounding plug that looks like the grounding plug as illustrated in Figure A below. A temporary adapter, which looks like the adapter as illustrated in Figures B and C below, may be used to connect this plug to a two-pole receptacle, as shown in Figure B if a properly grounded outlet is not available.** The temporary adapter should only be used until a properly grounded outlet can be installed by a qualified electrician. The green colored rigid ear or tab, extending from the adapter, must be connected to a permanent ground such as a properly grounded outlet box.

* Canadian electrical codes require extension cords to be certified SJT type or better.

** Use of an adapter in Canada is not acceptable.

Specifications:**JML-1014**

Stock Number	708351
Swing Over Bed (In.).....	10
Swing Over Tool Rest Base (In.)	7 1/2
Working Distance Between Centers (In.).....	14
Number of Speeds	6
Range of Speeds (RPM).....	500, 840, 1240, 1800, 2630, 3975
Headstock Spindle Threads (T.P.I.).....	1 x 8
Headstock Spindle Taper.....	MT2
Tailstock Spindle Taper	MT2
Hole Through Tailstock (In.).....	3/8
Tailstock Ram Travel (In.).....	2
Toolrest Length (In.).....	6
Motor	1/2 HP, 1Ph, 115V only
Overall Dimensions (In.)	24 5/8(L) x 7 1/4 (W) x 14 (H)
Net Weight (lbs. – approx.)	72
Shipping Weight (lbs. – approx.).....	74

Optional Accessories Available from JET**Chisels**

5 Piece Mini Set	709163
3 Piece Pen Turning Set	709160

Pen Kits**24K Gold Titanium Gold**

Twist Pen Kit	709004	709010
Plunger Type Pencil Kit.....	709005	709011
Mont Blanc Style Pen Kit.....	709006	709015
Mont Blanc Style Letter Opener	709007	709013

Pen Mandrel w/bushings.....	709014
Wood Blanks Exotic Hardwoods (5 piece).....	709021
Drill Bit 7mm.....	709123
Wax Pen Finishing Kit.....	709019
Insta-Cure Glue.....	709020
Pens from the Woodlathe Book	709123

Chucks

Original Nova™ Chuck & Insert	709345K
Companion Supernova™ Chuck & Insert	709346K

The specifications in this manual are given as general information and are not binding. JET Equipment and Tools reserves the right to effect, at any time and without prior notice, changes or alterations to parts, fittings, and accessory equipment deemed necessary for any reason whatsoever.

Uncrating

1. Remove contents from the shipping box.
2. Inspect contents for shipping damage and report damage, if any, to your distributor.
3. Be sure to keep the box and packing material should you need to pack the lathe for moving.
4. Do not clean the lathe with anything other than a damp cloth or a mild solvent. Use of heavy solvents, paint thinner, gasoline, etc. will damage painted surfaces.

Contents of the Shipping Carton:

- 1 - Lathe w/ motor and tailstock
- 1 - Tool rest
- 1 - Face plate
- 1 - Drift rod
- 1 - Live center
- 1 - Spur center
- 1 - Safety goggles
- 1 - Owner's manual
- 1 - Warranty card

Assembly

The JML-1014 is fully assembled and comes ready to use right out of the box. However, it is a good practice to thoroughly check the machine for loose fasteners, handles, etc. before use.

Controls

Tailstock Handwheel (A, Fig. 1) - turn clockwise to move tailstock spindle forward. Turn counter-clockwise to retract tailstock spindle.

Tailstock Spindle Lock (B, Fig. 1) - locks tailstock spindle. Release to adjust with handwheel.

Tailstock Lock (C, Fig. 1) - locks tailstock in position on the bed. Release to move tailstock assembly closer to or farther from the headstock.

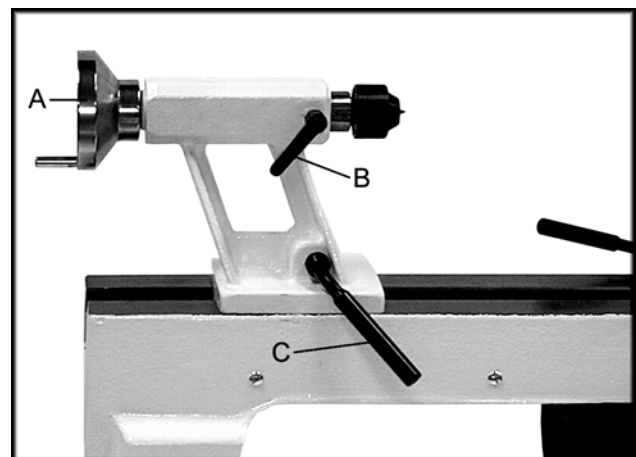

Fig. 1

Nomenclature and Use

Spur Center (A, Fig. 2) - locks into headstock and holds the workpiece during spindle turning.

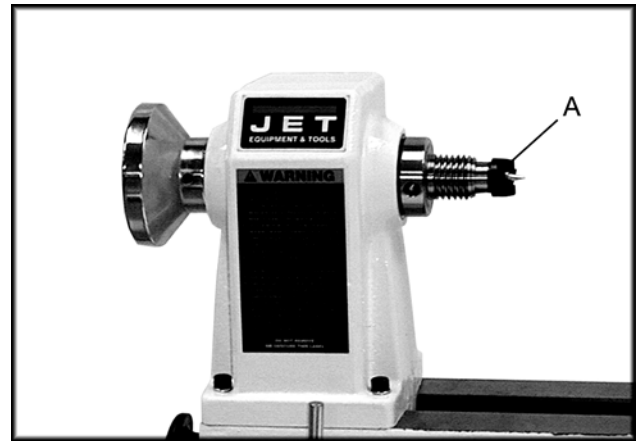

Fig. 2

Face Plate (A, Fig. 3) - attaches to headstock and is used in face plate turning operations.

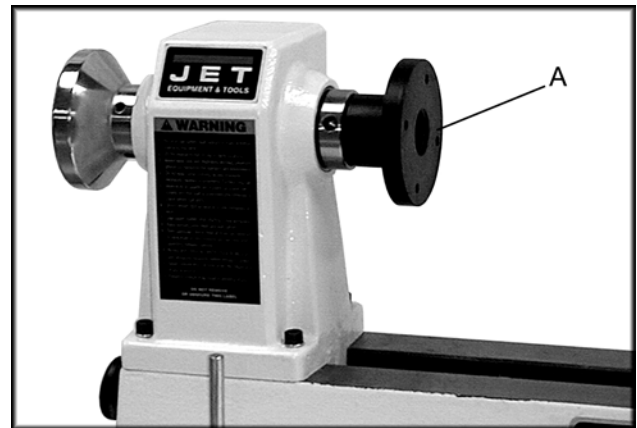

Fig. 3

Drift Rod (A, Fig. 4) - slides into the headstock to tap the spur center free. Stored in the hole in the base below the headstock.

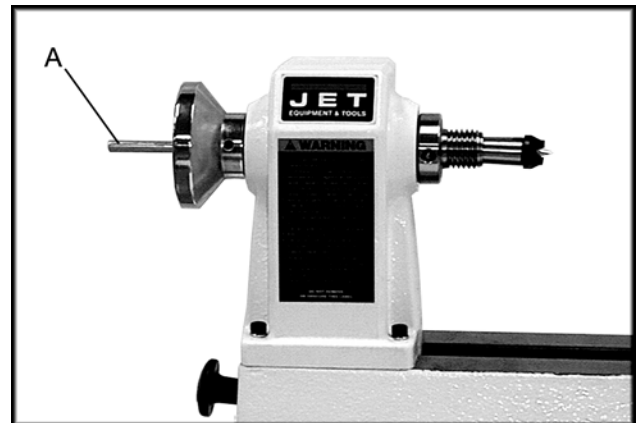

Fig. 4

Tool Rest (Fig. 5) - attaches to the bed. Used to steady cutting tool during spindle turning or face plate operations.

Adjusting the Tool Rest

Position the tool rest as close to the work piece as possible. It should be 1/8" above the centerline of the work piece.

Position the tool rest base on the bed by releasing the lock handle (A, Fig. 5) and sliding onto the desired position. Tighten handle (A, Fig. 5) to lock. Adjust the height of the tool rest by loosening handle (B, Fig. 5) and raising arm (C, Fig. 5).

Should adjustment of the tool rest clamping device become necessary, turn off the machine, reach under the bed, and adjust the clamping nut.

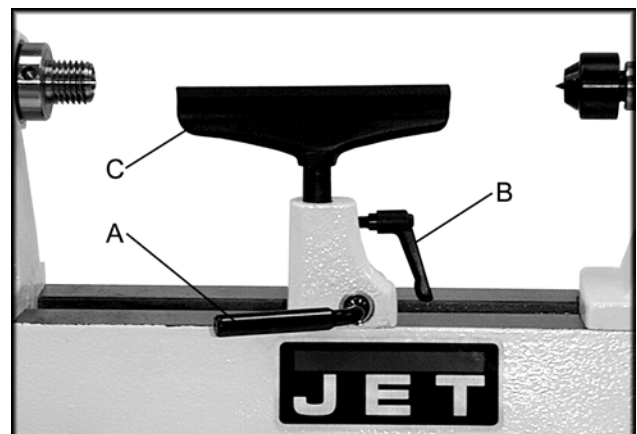

Fig. 5

Changing Spindle Speeds

1. Disconnect the machine from the power source (unplug).
2. Open the access doors at the left side of the base (A, Fig. 6), and at the back side of the headstock (A, Fig. 7).
3. Loosen the motor plate lock handle (A, Fig. 8). Lift up on the motor plate handle (B, Fig. 8) to take tension off the belt.
4. Move the belt (B, Fig. 6) to the desired pulley groove according to the speed chart found on the inside of the headstock access door. Be sure the belt is aligned with spindle pulley and motor pulley.
5. Tension the belt by pushing down on the motor plate handle (B, Fig. 8) and lock in place.

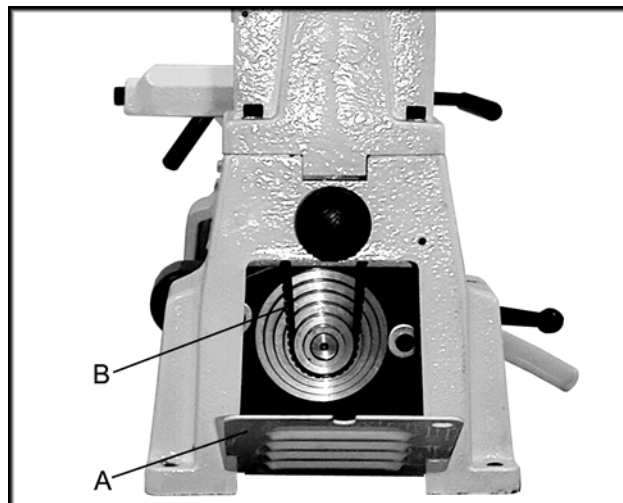

Fig. 6

Belt Replacement

1. Disconnect the machine from the power source (unplug).
6. Open the access doors at the left side of the base (A, Fig. 6), and at the back side of the headstock (A, Fig. 7).
2. Loosen the motor plate lock handle (A, Fig. 8). Lift up on the motor plate handle (B, Fig. 8) to take tension off the belt.
3. Loosen the set screw (B, Fig. 7) on spindle pulley (upper).
4. Loosen two set screws in handwheel (C, Fig. 7). Unscrew the handwheel while holding onto the spindle.
5. Remove handwheel and pull the spindle out while holding onto the spindle pulley.
6. Place the new belt on the spindle pulley. Place the spindle pulley back into the headstock the same way it was removed.

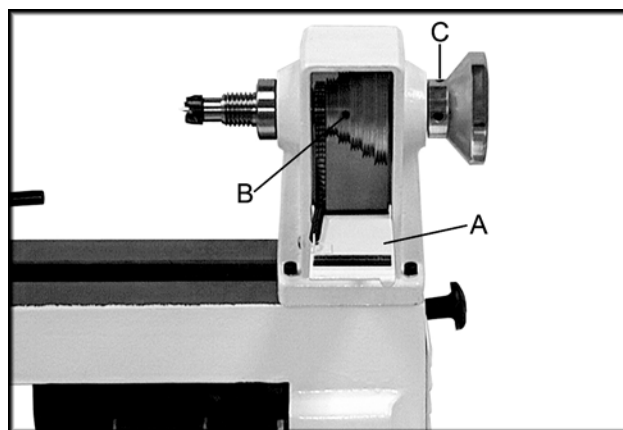

Fig. 7

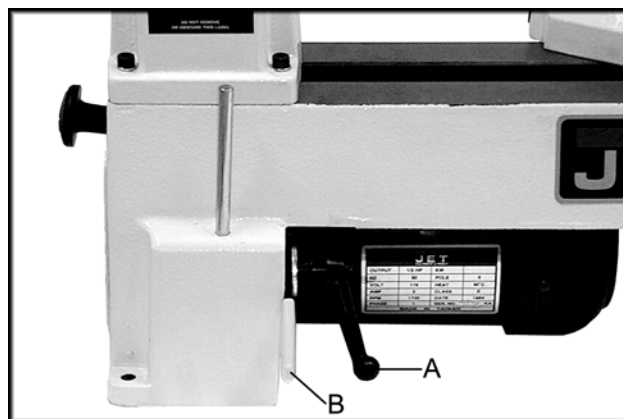

Fig. 8

7. Insert the spindle into the spindle pulley aligning the key.
8. Thread the handwheel onto the spindle leaving a little space between the handwheel and headstock. Tighten set screws.
9. Center the spindle pulley and tighten set screw.
10. Wrap the belt around the motor pulley (lower). Be sure the belt is aligned with spindle pulley and motor pulley.
11. Tension the belt and tighten the motor plate lock handle.

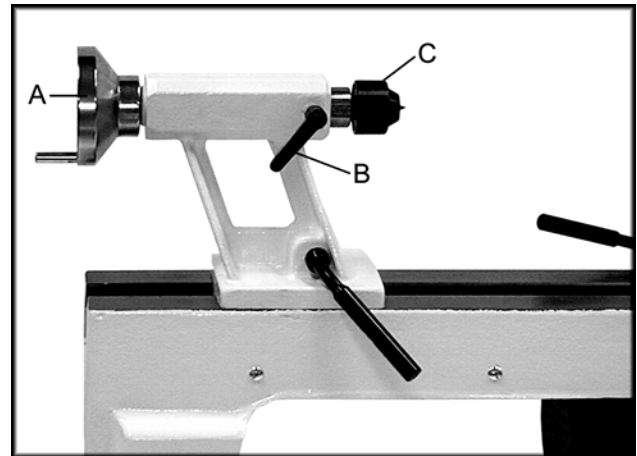

Fig. 9

Removing and Installing the Live Center

1. Loosen tailstock lock handle (B, Fig. 9).
2. Turn the tailstock handwheel (A, Fig. 9) counter-clockwise until the live center (C, Fig. 9) ejects from the spindle.
3. Before installing the live center into the spindle, the spindle must be extended out from the tailstock body far enough to allow the live center to “seat” in the spindle.

Parts List for the JML-1014 Mini Lathe

Index No.	Part No.	Description	Size	Qty.
1	JML-1	Headstock		1
	JML-1W	White Headstock		1
2	JML-2	Faceplate	3"	1
3	JML-3	Spur Center	MT2	1
	JML-3A	Center Point for Spur Center (not shown)		1
4	JML-4	Spindle	8 TPI	1
5	JML-5	Key	5x25	1
6	BB-6005VV	Ball Bearing		1
7	BB-6004VV	Ball Bearing		1
8	JML-8	Wave Washer		1
9	JML-9	Set Screw	1/4-20 x 3/8	6
10	JML-10	Handwheel		1
11	JML-11	Drift Rod		1
12	JML-12	Spindle Pulley Door		1
	JML-12W	White Spindle Pulley Door		1
13	JML-13	Spring		1
14	JML-14	Roll Pin	3 x 10	2
15	JML-15	Round Head Screw	3/16-24 x 5/8	2
16	JML-16	Hex Nut	3/16	1
17	JML-17	Hex Socket Cap Screw	1/4-20 x 3/4	4
18	JML-18	Lock Washer	1/4	4
19	JML-19	Spindle Pulley		1
20	JML-20	V-Belt		1
21	JML-21	Bed		1
	JML-21N	New White Bed		1
22	JML-22	Motor Pulley Door		1
	JML-22W	White Motor Pulley Door		1
23	JML-23	Lock Knob	M8	1
24	JML-24	Pin		1
25	JML-25	Flat Washer	M8	1
26	JML-26	Spring		1
27	JML-27	Hex Cap Screw		1
28	JML-28	Motor Pulley		1
29	JML-29	Hex Socket Cap Screw	1/4-20 x 5/8	2
30	JML-30	Flat Washer	1/4	2
31	JML-31	Lock Nut	5/16	1
32	JML-32	Hex Cap Bolt	5/16-18 x 1	1
33	JML-33	Motor Bracket		1
34	JML-34	Handle Protector		1
	JML-34W	White Handle Protector		1
35	JML-35	Motor		1
	JML-35-1	Capacitor (not shown)		1
	JML-35-2	Capacitor Cover (not shown)		1
	JML-35-3	Motor Fan Cover (not shown)		1
36	JML-36	Flat Washer	5/16	1
37	JML-37	Stud		1
38	JML-38	Handle		1
39	JML-39	Spring		1

40	JML-40	Stud	1
41	JML-41	Tool Rest Body	1
	JML-41W	White Tool Rest Body	1
42	JML-42	Tool Rest 6"	1
43	JML-43	Bolt	1
44	JML-44	Clamp	2
45	JML-45	Stud	1
46	JML-46	Handle	1
47	JML-47	Spring	1
48	JML-48	Stud	1
49	JML-49	C-Ring	2
50	JML-50	Eccentric Rod	1
51	JML-51	Bushing	1
52	JML-52	Live Center Head	1
	JML-52A	Center Point for Live Center (not shown)	1
53	BB-600ZZ	Ball Bearing	1
54	JML-54	Live Center Shaft	1
	708331	Live Center Assembly (not shown)	1
55	JML-55	Tailstock Spindle	1
56	JML-56	Leadscrew	1
57	JML-57	E-Ring	1
58	JML-58	Eccentric Rod	1
59	JML-59	Stud	1
60	JML-60	Tailstock	1
	JML-60W	White Tailstock	1
61	JML-61	Handwheel	1
62	JML-62	Handle	1
63	JML-63	C-Ring	1
64	JML-64	Bolt	1
65	JML-65	Safety Switch	1
66	JML-66	Round Head Screw 3/16-24 x 3/8	3
67	JML-67	Switch Bracket	1
68	JML-68	Round Head Machine Screw	2
69	JML-69	Switch Cover	1
70	JML-70	Stain Relief Bushing	2
71	JML-71	Hex Nut 3/16	2
72	JML-72	Cord Clamp	2
73	JML-73	Round Head Screw 3/16-24 x 1	2
74	JML-74	Cord Protector	1
75	JML-75	Power Cord	1
76	JML-76	Handle	1
77	JML-77	Spring	1
78	JML-78	Stud	1
79	JML-79	Safety Goggles	1
80	JML-80	Rubber Feet	4
81	JML-81	Clamp Nut	2
	JML-82	Warning Label (not shown)	1